

Alfa Laval Optigo CS

Commercial air coolers - slim line

General information & application

Optigo CS are commercial air coolers for general application in small to medium-sized cooling and freezing rooms. All CS models design are characterised by a low silhouette (only 15 cm for CS200) for the efficient use of cold room space. Optigo CS coolers are available from stock.

Evaporating temp.	+10 to -30°C
Refrigerants	all HFO/HFC DX and CO ₂ DX
Capacities (SC2)	550 up to 6850 W
Air volume	380 up to 3800 m ³ /h

Coil

Innovative coil manufactured from internally grooved Cu tubes, aluminium fins and dedicated thicker tubes for CO₂ applications. Tube pitch 30x26 mm staggered. Standard fin spacings 4 and 7 mm.

Casing

Durable aluminium alloy casing, white epoxy coated RAL 9002. Hinged drip tray construction. Pre-cut passages for multiple choice connections on both sides and top. All DX models fitted with a T-connection for better refrigerant distribution.

Fan motors

Standard fitted with plug-in dual fan speed EC motors in two diameters (200 and 300 mm). Fans pre-wired to the connection box. Power supply 230/1/50-60. Enclosed design spray-tight fan motors, protection class IP-54.

Options

Electric defrost (E), mounted as default for 7 mm, optional as a separate kit for 4 mm models.

Design pressure

Design pressure 40 bar (HFO/HFC, model CSE) or 80 bar (CO₂, model CSX). Each heat exchanger is leak tested with dry air and finally supplied with a nitrogen pre-charge.



Optigo CS200 (top) and CS300

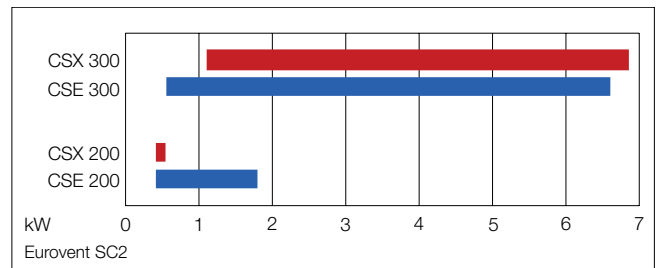

Benefits

- Available from stock.
- Low silhouette for efficient use of cold room space.
- Sufficient space for expansion valve inside casing.
- Eurovent certified performance (CSE models only).
- Energy efficient EC plug-in fans.
- Fans pre-wired to the connection box.
- Two-year product guarantee.
- Easy access to on-line product information (QR code).

По вопросам продаж и поддержки обращайтесь:

Архангельск (8182)63-90-72
Астана +7(7172)727-132
Астрахань (8512)99-46-04
Барнаул (3852)73-04-60
Белгород (4722)40-23-64
Брянск (4832)59-03-52
Владивосток (423)249-28-31
Волгоград (844)278-03-48
Вологда (8172)26-41-59
Воронеж (473)204-51-73
Екатеринбург (343)384-55-89
Иваново (4932)77-34-06
Ижевск (3412)26-03-58
Иркутск (395) 279-98-46

Казань (843)206-01-48
Калининград (4012)72-03-81
Калуга (4842)92-23-67
Кемерово (3842)65-04-62
Киров (8332)68-02-04
Краснодар (861)203-40-90
Красноярск (391)204-63-61
Курск (4712)77-13-04
Липецк (4742)52-20-81
Магнитогорск (3519)55-03-13
Москва (495)268-04-70
Мурманск (8152)59-64-93
Набережные Челны (8552)20-53-41
Нижний Новгород (831)429-08-12

Новокузнецк (3843)20-46-81
Новосибирск (383)227-86-73
Омск (3812)21-46-40
Орел (4862)44-53-42
Оренбург (3532)37-68-04
Пенза (8412)22-31-16
Пермь (342)205-81-47
Ростов-на-Дону (863)308-18-15
Рязань (4912)46-61-64
Самара (846)206-03-16
Санкт-Петербург (812)309-46-40
Саратов (845)249-38-78
Севастополь (8692)22-31-93
Симферополь (3652)67-13-56

Смоленск (4812)29-41-54
Сочи (862)225-72-31
Ставрополь (8652)20-65-13
Сургут (3462)77-98-35
Тверь (4822)63-31-35
Томск (3822)98-41-53
Тула (4872)74-02-29
Тюмень (3452)66-21-18
Ульяновск (8422)24-23-59
Уфа (347)229-48-12
Хабаровск (4212)92-98-04
Челябинск (351)202-03-61
Череповец (8202)49-02-64
Ярославль (4852)69-52-93

Киргизия (996)312-96-26-47

Казахстан (772)734-952-31

Таджикистан (992)427-82-92-69

Эл. почта: afm@nt-rt.ru || Сайт: <http://alfa-laval.nt-rt.ru>

Optigo model	fin spacing	nr. of fans	Fan speed H								Fan speed L		Dimensions mm		
			capacities ¹⁾		air flow	coil surface	weight	fan power	air throw	sound press. ²⁾	fan power	sound press. ²⁾	Refrig. conn.		
			SC1	SC2									inlet	suction	OD
CSE	mm		kW	kW	m ³ /h	m ²	kg	W	m	dB(A)	W	dB(A)	L	OD	OD
201 B 4	4	1	1.3	0.9	515	2.8	7	33	5.7	43	19	37	580	12	12
202 B 4	4	2	2.6	1.8	1030	5.6	14	66	8.0	46	38	40	1030	12	12
301 B 4	4	1	2.1	1.4	763	4.7	12	35	6.5	42	17	33	865	12	12
301 C 4	4	1	2.5	1.7	667	7.0	12	35	5.7	42	17	33	865	12	12
302 B 4	4	2	3.9	2.7	1525	9.4	16	70	9.2	45	34	36	1365	12	14
302 C 4	4	2	5.0	3.4	1334	14.0	18	70	8.1	45	34	36	1365	16	16
303 B 4	4	3	6.2	4.3	2287	14.0	21	105	11.3	47	51	38	1865	16	16
303 C 4	4	3	7.0	4.8	2002	21.1	24	105	9.9	47	51	38	1865	16	18
304 C 4	4	4	9.6	6.6	2669	28.1	29	140	11.4	48	68	39	2365	16	20
201 B 7	7	1	1.0	0.7	559	1.7	7	33	6.2	43	19	37	580	12	12
202 B 7	7	2	1.9	1.3	1119	3.4	14	66	8.7	46	38	40	1030	12	12
301 B 7	7	1	1.5	1.0	848	2.8	12	35	7.2	42	17	33	865	12	12
301 C 7	7	1	2.0	1.3	762	4.2	12	35	6.5	42	17	33	865	12	12
302 B 7	7	2	3.0	2.0	1696	5.6	17	70	10.2	45	34	36	1365	12	14
302 C 7	7	2	4.0	2.7	1523	8.5	18	70	9.2	45	34	36	1365	16	16
303 B 7	7	3	4.6	3.1	2544	8.5	22	105	12.5	47	51	38	1865	16	16
303 C 7	7	3	5.8	3.9	2285	12.7	24	105	11.2	47	51	38	1865	16	18
304 C 7	7	4	7.8	5.3	3047	16.9	30	140	13.0	48	68	39	2365	16	20
305 C 7	7	5	9.4	6.4	3808	21.1	36	175	14.5	49	85	40	2865	16	22

1) Capacities SC1: R-404A/R-507A, t₀=0 °C, DT1=10K. SC2: R-404A/R-507A, t₀=-8 °C, DT1=8K, lightly frosted coil.

2) Sound pressure values according to EN 13487 Lp(A) at 3m.

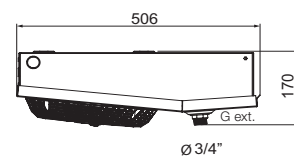
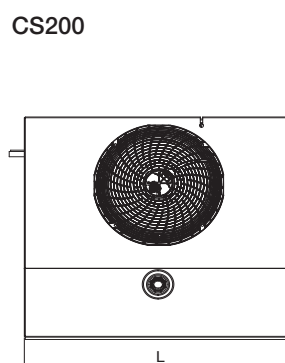
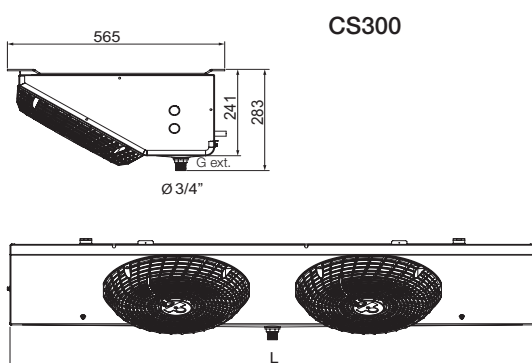

Code description

CS	E	H	20	2	B	S	230V	BO	AL	E	CB	-	AL	7.0	CU
1	2	3	4	5	6	7	8	9	10	11	12		13	14	15

- Commercial air cooler - slim line
- Refrigerant system (E=HFO/HFC DX, X=CO₂ DX)
- Fan speed (H=high speed, L=low fan speed)
- Fan diameter (20=200, 30=300 mm)
- Number of fans (1 to 5)
- Tube rows code (B, C)
- No. of phases (S=1)
- Motor voltage
- Packing (BO=box)
- Casing material (AL=epoxy coated aluminium)
- Defrost system (E=electric defrost, blank=air defrost)
- Connection box (CB)
- Fin material (AL=aluminium)
- Fin spacing (4.0, 7.0 mm)
- Tube material (CU=copper)

Selection

Selection and pricing is to be performed with our Alfa Laval air heat exchanger selection software. Selection output includes all relevant technical data and dimensional drawings.

Certifications

Eurovent certified performance for models included in the scope of the programme. The Alfa Laval quality system is in accordance with ISO 9001. All products are manufactured according to PED regulations.



Архангельск (8182)63-90-72
 Астана +7(7172)727-132
 Астрахань (8512)99-46-04
 Барнаул (3852)73-04-60
 Белгород (4722)40-23-64
 Брянск (4832)59-03-52
 Владивосток (423)249-28-31
 Волгоград (844)278-03-48
 Вологда (812)26-41-59
 Воронеж (473)204-51-73
 Екатеринбург (343)384-55-89
 Иваново (4932)77-34-06
 Ижевск (3412)26-03-58
 Иркутск (395) 279-98-46

Казань (843)206-01-48
 Калининград (4012)72-03-81
 Калуга (4842)92-23-67
 Кемерово (3842)65-04-62
 Киров (8332)68-02-04
 Краснодар (861)203-40-90
 Красноярск (391)204-63-61
 Курск (4712)77-13-04
 Липецк (4742)52-20-81
 Магнитогорск (3519)55-03-13
 Москва (495)268-04-70
 Мурманск (8152)59-64-93
 Набережные Челны (8552)20-53-41
 Нижний Новгород (831)429-08-12

Новокузнецк (3843)20-46-81
 Новосибирск (383)227-86-73
 Омск (3812)21-46-40
 Орел (4862)44-53-42
 Оренбург (3532)37-68-04
 Пенза (8412)22-31-16
 Пермь (342)205-81-47
 Ростов-на-Дону (863)308-18-15
 Рязань (4912)46-61-64
 Самара (846)206-03-16
 Санкт-Петербург (812)309-46-40
 Саратов (845)249-38-78
 Севастополь (8692)22-31-93
 Симферополь (3652)67-13-56

Смоленск (4812)29-41-54
 Сочи (862)225-72-31
 Ставрополь (8652)20-65-13
 Сургут (3462)77-98-35
 Тверь (4822)63-31-35
 Томск (3822)98-41-53
 Тула (4872)74-02-29
 Тюмень (3452)66-21-18
 Ульяновск (8422)24-23-59
 Уфа (347)229-48-12
 Хабаровск (4212)92-98-04
 Челябинск (351)202-03-61
 Череповец (8202)49-02-64
 Ярославль (4852)69-52-93

Киргизия (996)312-96-26-47

Казахстан (772)734-952-31

Таджикистан (992)427-82-92-69

Эл. почта: afm@nt-rt.ru || Сайт: <http://alfa-laval.nt-rt.ru>