

Alfa Laval DIABON®

Graphite plate heat exchanger

Applications

Heaters, coolers, interchangers, condensers and evaporators for corrosive media, especially in the treatment of:

- Hydrochloric acid (HCl)
- Sulfuric acid (H₂SO₄)
- Hydrofluoric acid (HF)
- Mixed Acids (HNO₃/HF)
- Phosphoric acid (H₃PO₄/P₂O₅)
- Other organic and inorganic media

Standard design

The graphite plate heat exchanger consists of a pack of corrugated graphite plates with portholes for the passage of the two fluids between which heat transfer will take place.

The plate pack is assembled between a carbon steel fixed frame plate and movable pressure plate and compressed by tightening bolts. The difference in coefficients of expansion of carbon steel and graphite is compensated for by means of helical springs.

The plates are fitted with a film type PTFE gasket of 0,2 mm thickness after tightening, which seals the interplate channel and directs the fluids into alternate channels. The number of plates is determined by the flow rate, pressure drop and temperature program. The plate corrugations promote fluid turbulence and minimize fouling.

The frame plate and pressure plates are suspended from an upper carrying bar and located by a lower guiding bar, both of which are fixed to a support column. Connections are located in the frame plate or, if either or both fluids make more than a single pass within the unit, in the frame and pressure plates.

The frame and pressure plates are protected from the corrosive media by means of a PTFE lining.

Typical capacities

Max flow rate of 250 m³/h, depending on media, permitted pressure drop and temperature program.



Plate types: S1, M10-G, S10, S15.

Frame types: One standard frame available that can be modified to higher design pressures.

Working principle

Channels are formed between the plates and the corner ports are arranged so that the two media flow through alternate channels. The heat is transferred through the plate between the channels, and complete counter current flow is created for the highest possible efficiency. The corrugation of the plates provides the passage between the plates, supports each plate against the adjacent one and enhances the turbulence, resulting in efficient heat transfer.

Standard materials

Plates: F100, NS1/NS2

По вопросам продаж и поддержки обращайтесь:

Архангельск (8182)63-90-72
Астана +7(7172)727-132
Астрахань (8512)99-46-04
Барнаул (3852)73-04-60
Белгород (4722)40-23-64
Брянск (4832)59-03-52
Владивосток (423)249-28-31
Волгоград (844)278-03-48
Вологда (8172)26-41-59
Воронеж (473)204-51-73
Екатеринбург (343)384-55-89
Иваново (4932)77-34-06
Ижевск (3412)26-03-58
Иркутск (395) 279-98-46

Казань (843)206-01-48
Калининград (4012)72-03-81
Калуга (4842)92-23-67
Кемерово (3842)65-04-62
Киров (8332)68-02-04
Краснодар (861)203-40-90
Красноярск (391)204-63-61
Курск (4712)77-13-04
Липецк (4742)52-20-81
Магнитогорск (3519)55-03-13
Москва (495)268-04-70
Мурманск (8152)59-64-93
Набережные Челны (8552)20-53-41
Нижний Новгород (831)429-08-12

Новокузнецк (3843)20-46-81
Новосибирск (383)227-86-73
Омск (3812)21-46-40
Орел (4862)44-53-42
Оренбург (3532)37-68-04
Пенза (8412)22-31-16
Пермь (342)205-81-47
Ростов-на-Дону (863)308-18-15
Рязань (4912)46-61-64
Самара (846)206-03-16
Санкт-Петербург (812)309-46-40
Саратов (845)249-38-78
Севастополь (8692)22-31-93
Симферополь (3652)67-13-56

Смоленск (4812)29-41-54
Сочи (862)225-72-31
Ставрополь (8652)20-65-13
Сургут (3462)77-98-35
Тверь (4822)63-31-35
Томск (3822)98-41-53
Тула (4872)74-02-29
Тюмень (3452)66-21-18
Ульяновск (8422)24-23-59
Уфа (347)229-48-12
Хабаровск (4212)92-98-04
Челябинск (351)202-03-61
Череповец (8202)49-02-64
Ярославль (4852)69-52-93

Киргизия (996)312-96-26-47

Казахстан (772)734-952-31

Таджикистан (992)427-82-92-69

Эл. почта: afm@nt-rt.ru || Сайт: <http://alfa-laval.nt-rt.ru>

F100

DIABON® F100 plates are suitable for operations where fouling can be a problem as well as for oxidising environments.

The DIABON® F100 plates are pressure moulded with a herringbone plate pattern on both sides which gives rise to very efficient turbulence. Erosion risk is minimized due to a hard plate surface. The PVDF encapsulating of the graphite grains yields plates with a very smooth, non-porous and anti-adhesive surface and provides more resistance against oxidising media.

F100

Plate material

Graphite + PVDF

Graphite encapsulated in a fluoroplastic binder

Pressure-moulded

Herringbone pattern

Smooth surface

Good against erosion

Anti fouling surface

Tdes = 140 °C

Ptest 9,1 barg, Pdes = approximately 7 barg

(Ptest = 10,4 barg, special)

Application

Better with oxidizing media

PVDF not good with

- amines & NaOH

- organic chem. (case to case basis)

S1, M10-G, S10

- Thermal fatigue

- Lower max. temperature

Plate Gaskets: PTFE, plastic

Frame plate: Carbon Steel, P265GH or SA516 Gr. 60

Guide bars: 1.4301 (SS grade)

Compression springs: 51CrV4

Nozzels: Lining of frame/pressure plates and connections:
PTFE (Licuflon)

NS1/NS2

NS1 and NS2 grade plates are preferred for 2 phase applications and/or duties with higher variations in temperature.

The NS1 and NS2 plate pattern is machined from blocks of resin impregnated material. The plates are flat on one side and have a fin-plate pattern on the side facing the pressure plate. The plate pattern has very few contact points which makes the plates more suitable for fluids containing fibres. The resin impregnated graphite in these plates is less sensitive to thermal fatigue and can handle high temperature differences. These plates are not suitable for oxidising media.

NS1 (NS2)

Plate material

Resin impregnated graphite

Same material as used in S&T and block heat exchangers

Machined plates

Plate fin type

"If touched - you're black"

Tdes = 200 °C

Ptest 9,1 barg, Pdes = approximately 7 barg

(Ptest = 10,4 barg, special)

Application

No nitric acid

DIABON® NS2 better than NS1

- organic chem. (case to case basis)

S1-N, M10-GN, S10-N, S15-N

+ Steam heating

+ Higher max. temperature

Technical data

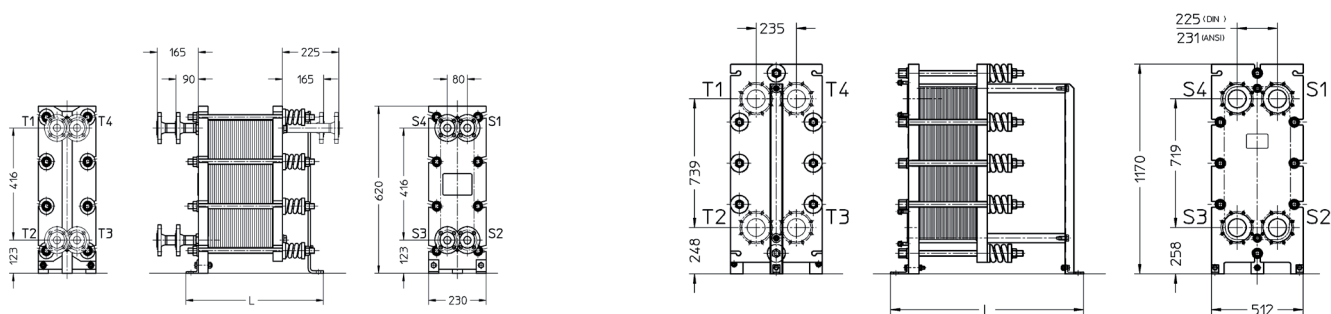

DIABON® graphite plate heat exchanger S1

DIABON® graphite plate heat exchanger M10-G

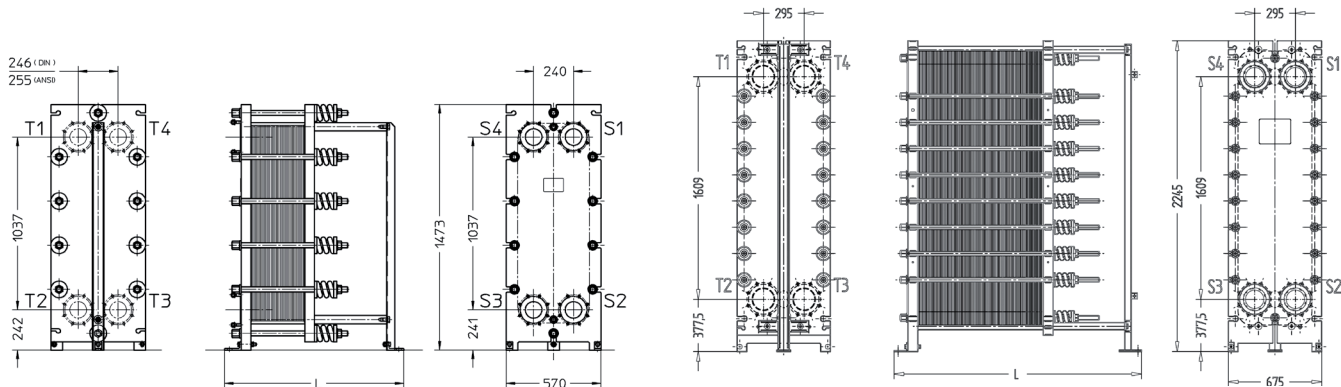

DIABON® graphite plate heat exchanger S10

DIABON® graphite plate heat exchanger S15

Plates

Property	Unit	DIABON® graphite plate heat exchanger S1		DIABON® graphite plate heat exchanger M10-G	
		DIABON® F100	DIABON® NS1 (NS2)	DIABON® F100	DIABON® NS1 (NS2)
Corrugation pattern		turbulent flow	free flow	turbulent flow (high and low theta)	free flow
Typical heat transition coefficients	W/K-m ²	2000	4500	2200	4500
Exchange area per plate	m ²	0.05	0.03	0.25	0.18
Max. no. of plates per frame		80	64	160	100
Plate thickness	mm	8	10	6.5	10
Liquid capacity	l	0.18	0.12	0.7	0.6
Weight of a plate	kg	0.75	0.95	2.7	4.2
Plate Seals		SIGRAFLEX® graphite	SIGRAFLEX® graphite	PTFE, plastic	PTFE, plastic

Frame

Property	Unit	DIABON® graphite plate heat exchanger S1		DIABON® graphite plate heat exchanger M10-G	
		DIABON® F100	DIABON® NS1 (NS2)	DIABON® F100	DIABON® NS1 (NS2)
Width x height	mm	230 x 620		512 x 1170	
Length L	mm	350/450/550/650/750/850		912/1162/1512/1762	
Max. no. of plates for length L		18/30/43/55/68/80	14/24/34/44/54/64	32/70/125/160	20/45/80/100
Weight excl. DIABON® graphite	kg	105-125		610-650	
Connections – frame plate or pressure plate	S1-S4 T1-T4	DN 100 (DN 80) DIN EN 1092-1 PN16 or DN 1" ANSI 150 lbs		DN 25 DIN EN 1092-1 PN16 or DN 4" (DN 3") ANSI 150 lbs	
Test pressure with water	bar	standard: 9.1/special design: 10.4		standard: 9.1/special design: 10.4	
Design temperature	°C	140	200	140	200

Plates

Property	Unit	DIABON® graphite plate heat exchanger S10		DIABON® graphite plate heat exchanger S15
		DIABON® F100	DIABON® NS1 (NS2)	DIABON® NS1 (NS2)
Corrugation pattern		turbulent flow	free flow	free flow
Typical heat transition coefficients	W/K-m ²	2000	4000	4000
Exchange area per plate	m ²	0.4	0.30	0.63
Max. no. of plates per frame		130	96	90
Plate thickness	mm	8	10	10
Liquid capacity	l	1.5	1.4	2.6
Weight of a plate	kg	6.1	7.1	15.3
Plate seals		PTFE, plastic	PTFE, plastic	PTFE, plastic

Frame

Property	Unit	DIABON® graphite plate heat exchanger S10		DIABON® graphite plate heat exchanger S15
		DIABON® F100	DIABON® NS1 (NS2)	DIABON® NS1 (NS2)
Width x height	mm	570 x 1473	570 x 1473	675 x 2245
Length L	mm	912/1162/1512/1762	912/1162/1512/1762	942/1192/1542/1792
Max. no. of plates for length L		25/55/100/130	16/40/72/96	16/32/66/90
Weight excl. DIABON® graphite	kg	900-940	900-940	1500-2300
Connections – frame plate	S1-S4	DN 100 DIN EN 1092-1 PN16		DN 150 DIN EN1092-1 PN16
or pressure plate	T1-T4	or DN 4" ANSI 150 lbs		or DN 6" ANSI 150 lbs
Test pressure with water	bar	standard: 9.1/special design: 10.4		standard: 9.1/special design: 10.4
Design temperature	°C	140	200	200

Materials

Frame and pressure plates	P265GH or SA516 Gr. 60
Tie rods and stud bolts	21CrMoV57 alt. SA193 Gr. B7
Nuts	25CrMo4V alt. SA194 2H
Compression springs	51CrV4
Guide bars	1.4301 (stainless steel grade)
Lining of frame/pressure plates and connections	PTFE (LICUFLON)
Painting	2-component epoxy paint
	1 priming coat of Hempadur 15570, 100 µm
	1 intermediate coat of Hempadur 15570, 100 µm
	1 top coat of Hempthane 55210, 60 µm
	shade: similar to RAL 5002

DIABON® graphite plate heat exchangers are manufactured in accordance with Pressure Equipment Directive 97/23/EC, categories I to III, module B (EC type testing of series-produced pressure vessels) and C1 (conformity to design). The design calculations for our plate heat exchangers are based on specifications AD 2000-Regelwerk.

Архангельск (8182)63-90-72
 Астана +7(7172)727-132
 Астрахань (8512)99-46-04
 Барнаул (3852)73-04-60
 Белгород (4722)40-23-64
 Брянск (4832)59-03-52
 Владивосток (423)249-28-31
 Волгоград (844)278-03-48
 Вологда (8172)26-41-59
 Воронеж (473)204-51-73
 Екатеринбург (343)384-55-89
 Иваново (4932)77-34-06
 Ижевск (3412)26-03-58
 Иркутск (395) 279-98-46

Казань (843)206-01-48
 Калининград (4012)72-03-81
 Калуга (4842)92-23-67
 Кемерово (3842)65-04-62
 Киров (8332)68-02-04
 Краснодар (861)203-40-90
 Красноярск (391)204-63-61
 Курск (4712)77-13-04
 Липецк (4742)52-20-81
 Магнитогорск (3519)55-03-13
 Москва (495)268-04-70
 Мурманск (8152)59-64-93
 Набережные Челны (8552)20-53-41
 Нижний Новгород (831)429-08-12

Новокузнецк (3843)20-46-81
 Новосибирск (383)227-86-73
 Омск (3812)21-46-40
 Орел (4862)44-53-42
 Оренбург (3532)37-68-04
 Пенза (8412)22-31-16
 Пермь (342)205-81-47
 Ростов-на-Дону (863)308-18-15
 Рязань (4912)46-61-64
 Самара (846)206-03-16
 Санкт-Петербург (812)309-46-40
 Саратов (845)249-38-78
 Севастополь (8692)22-31-93
 Симферополь (3652)67-13-56

Смоленск (4812)29-41-54
 Сочи (862)225-72-31
 Ставрополь (8652)20-65-13
 Сургут (3462)77-98-35
 Тверь (4822)63-31-35
 Томск (3822)98-41-53
 Тула (4872)74-02-29
 Тюмень (3452)66-21-18
 Ульяновск (8422)24-23-59
 Уфа (347)229-48-12
 Хабаровск (4212)92-98-04
 Челябинск (351)202-03-61
 Череповец (8202)49-02-64
 Ярославль (4852)69-52-93

Киргизия (996)312-96-26-47

Казахстан (772)734-952-31

Таджикистан (992)427-82-92-69

Эл. почта: afm@nt-rt.ru || Сайт: <http://alfa-laval.nt-rt.ru>